

SECTION A

This question consists of TWENTY FIVE sub-questions, 1.1 to 1.25, of ONE mark each. For each of the sub-questions, four alternatives, A, B, C and D are provided. Choose the most appropriate alternative and darken its bubble on the OBJECTIVE RESPONSE SHEET.

1.1 The rank of the matrix $\begin{bmatrix} 1 & 1 \\ 0 & 0 \end{bmatrix}$ is

- (A) 4 (C) 1
(B) 2 (D) 0

1.2 The trapezoidal rule for integration give exact result when the integrand is a polynomial of degree

- (A) But not 1 (C) 0 or 1
(B) 1 but not 0 (D) 2

1.3 The solution to the recurrence equation $T(2^k) = 3T(2^{k-1}) + 1$, $T(1)$ is

- (A) 2^k (C) $3^{\log_2 k}$
(B) $(3^{k+1} - 1)/2$ (D) $2^{\log_3 k}$

1.4 The minimum number of colours required to colour the vertices of a cycle with n nodes in such a way that no two adjacent nodes have the same colour will be:

- (A) 2 (C) 4
(B) 3 (D) $n - 2 \lfloor n/2 \rfloor + 2$

1.5 In the worst case, the number of comparisons needed to search a singly linked list of length n for a given element is

- (A) $\log_2 n$ (C) $\log_2 n - 1$
(B) $n/2$ (D) n

1.6 Which of the following is true?

- (A) The set of all rational negative numbers forms a group under multiplication.
(B) The set of all non-singular matrices forms a group under multiplication.
(C) The set of all matrices forms a group under multiplication.
(D) Both B and C are true.

1.7 The language accepted by a Pushdown Automaton in which the stack is limited to 10 items is best described as

- (A) Context free (C) Deterministic Context free
(B) Regular (D) Recursive

1.8 “If X, then Y unless Z” is represented by which of the following formulae in propositional logic? (“¬” is negation “∧” is conjunction, and “→” is implication)

- (A) $(X \wedge \neg Z) \rightarrow Y$ (C) $(X \rightarrow (Y \wedge \neg Z))$
 (B) $(X \wedge Y) \rightarrow \neg Z$ (D) $(X \rightarrow Y \wedge \neg Z)$

1.9 A device employing INTR line for device interrupt puts the CALL instruction on the data bus while

- (A) \overline{INTA} is active (D) None of the these
 (B) HOLD is active
 (C) READY is active

1.10 In 8085, which of the following modifies the program counter?

- (A) Only PCHL instruction (C) Only JMP and CALL instructions
 (B) Only ADD instructions (D) All instructions

1.11 In serial data transmission, every byte of data is padded with a '0' in the beginning and one or two '1's at the end of byte because

- (A) Receiver is to be synchronized for byte reception
 (B) Receiver recovers lost '0's and '1's from these padded bits
 (C) Padded bits are useful in parity computation
 (D) None of the these.

1.12 Minimum sum of product expression for $f(w,x,y,z)$ shown in Karnaugh-map below is

	wx			
yz	00	01	11	10
00	0	1	1	0
01	×	0	0	1
11	×	0	0	1
10	0	1	1	×

- (A) $xz + y'z$ (C) $x'y + zx'$
 (B) $xz' + zx'$ (D) None of these

- 1.13 Which of the following is not a form of memory?
- (A) instruction cache
 - (B) instruction register
 - (C) instruction opcode
 - (D) translation lookaside buffer
- 1.14 The decimal value 0.25
- (A) is equivalent to the binary value 0.1
 - (B) is equivalent to the binary value 0.01
 - (C) is equivalent to the binary value 0.00111...
 - (D) cannot be represented precisely in binary
- 1.15 The 2's complement representation of the decimal value -15 is
- (A) 1111
 - (B) 11111
 - (C) 111111
 - (D) 10001
- 1.16 Sign extension is a step in
- (A) floating point multiplication
 - (B) signed 16 bit integer addition
 - (C) arithmetic left shift
 - (D) converting a signed integer from one size to another
- 1.17 In the C language
- (A) At most one activation record exists between the current activation record and the activation record for the main.
 - (B) The number of activation records between the current activation record and the activation record for the main depends on the actual function calling sequence.
 - (C) The visibility of global variables depends on the actual function calling sequence.
 - (D) Recursion requires the activation record for the recursive function to be saved on a different stack before the recursive function can be called.
- 1.18 The results returned by functions under value-result and reference parameter passing conventions
- (A) Do not differ
 - (B) Differ in the presence of loops
 - (C) Differ in all cases
 - (D) May differ in the presence of exceptions.

- 1.19 Relation R with an associated set of functional dependencies, F is decomposed into BCNF. The redundancy (arising out of functional dependencies) in the resulting set relations is
- (A) Zero
 - (B) More than zero but less than that of an equivalent 3NF decomposition
 - (C) Proportional to the size of F^+
 - (D) Indeterminate
- 1.20 With regard to the expressive power of the formal relational query languages, which of the following statements is true?
- (A) Relational algebra is more powerful than relational calculus
 - (B) Relational algebra has the same power as relational calculus.
 - (C) Relational algebra has the same power as safe relational calculus.
 - (D) None of the above
- 1.21 In 2's complement addition, overflow
- (A) is flagged whenever there is carry from sign bit addition
 - (B) cannot occur when a positive value is added to a negative value
 - (C) is flagged when the carries from sign bit and previous bit match
 - (D) None of the above
- 1.22 Which of the following scheduling algorithms is non-preemptive?
- (A) Round Robin
 - (B) First-In First-Out
 - (C) Multilevel Queue Scheduling
 - (D) Multilevel Queue Scheduling with Feedback
- 1.23 The optimal page replacement algorithm will select the page that
- (A) Has not been used for the longest time in the past.
 - (B) Will not be used for the longest time in the future.
 - (C) Has been used least number of times.
 - (D) Has been used most number of times.
- 1.24 In the absolute addressing mode
- (A) The operand is inside the instruction
 - (B) The address of the operand is inside the instruction
 - (C) The register containing address of the operand is specified inside the instruction
 - (D) The location of the operand is implicit

1.25 Maximum number of edges in a n-node undirected graph without self loops is

- (A) n^2
- (B) $n(n-1) / 2$
- (C) $n - 1$
- (D) $(n + 1) (n) / 2$

This question consists of TWENTY FIVE sub-questions, 2.1 to 2.25, of TWO marks each. For each of the sub-questions, four alternatives, A,B,C and D are provided. Choose the most appropriate alternative and darken its bubble on the OBJECTIVE RESPONSE SHEET

2.1 Consider the following logic circuit whose inputs are functions and output is f.

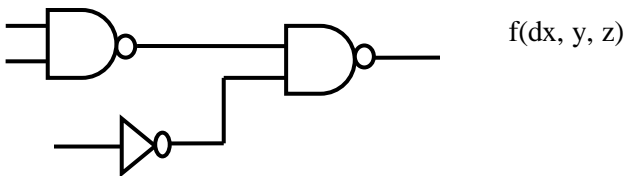

$f_1 (dx, y, z)$

$f_2(dx, y, z)$

$f_3(dx, y,z) = ?$

Given that

$f_1 (dx, y, z) = \Sigma (d0, 1, 3, 5)$

$f_2(dx, y, z) = \Sigma(d6, 7)$ and

$f(dx, y,z) = \Sigma(d1, 4, 5),$

f_3 is

(A) $\Sigma (1, 4, 5)$

(B) $\Sigma (6, 7)$

(C) $\Sigma(0, 1, 3, 5)$

(D) None of these

2.2 Consider the following multiplexor where 10, 11, 12, 13 are four data input lines selected by two address line combinations A1A0 =00,01,10,11 respectively and f is “the output of the multiplexor. EN is the Enable input.

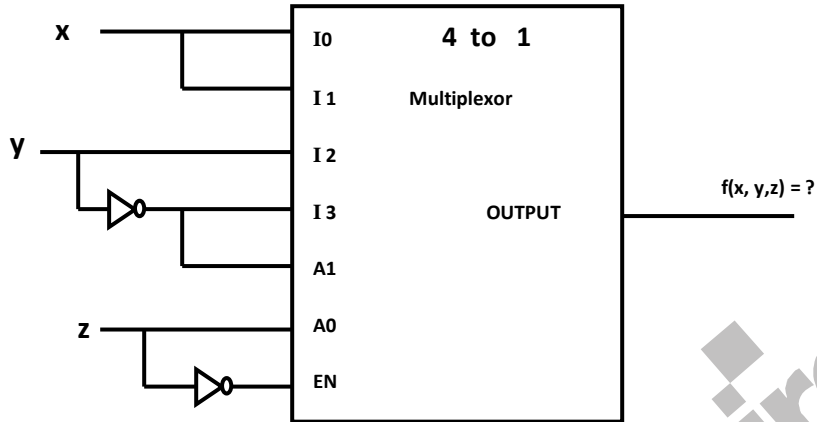

The function $f(x, y, z)$ implemented by the above circuit is

- (A) xyz'
- (B) $xy + z$
- (C) $x + y$
- (D) None of these

2.3 Let $f(A,B) = A' + B$. Simplified expression for function $f(f(x + y, y)z)$ is

- (A) $x' + z$
- (B) xyz
- (C) $xy' + z$
- (D) None of these

2.4 What are the states of the Auxiliary Carry (AC) and Carry Flag (CY) after executing the following 8085 program?

```

MVI    H,    5DH
MVI    L,    6BH
MOV    A,    H
ADD    L
    
```

- (A) AC = 0 and CY = 0
- (B) AC = 1 and CY = 1
- (C) AC = 1 and CY = 0
- (D) AC = 0 and CY = 0

2.5 The finite state machine described by the following state diagram with A as starting state, where an arc label is x/y and x stands for 1-bit input and y stands for 2-bit output

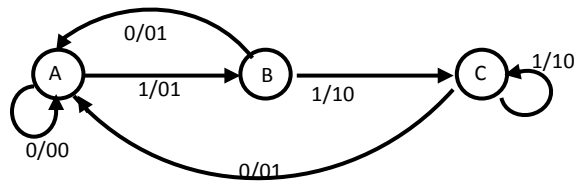

- (A) Outputs the sum of the present and the previous bits of the input.
 (B) Outputs 01 whenever the input sequence contains 11
 (C) Outputs 00 whenever the input sequence contains 10
 (D) None of these
- 2.6 The performance of a pipelined processor suffers if
 (A) the pipeline stages have different delays
 (B) consecutive instructions are dependent on each other
 (C) the pipeline stages share hardware resources
 (D) all of the above
- 2.7 Horizontal microprogramming
 (A) does not require use of signal decoders
 (B) results in larger sized microinstructions than vertical microprogramming
 (C) uses one bit for each control signal
 (D) all of the above
- 2.8 Consider the following declaration of a two-dimensional array in C:
`char a[100][100];`
 Assuming that the main memory is byte-addressable and that the array is stored starting from memory address 0, the address of a [40][50] is
 (A) 4040 (C) 5040
 (B) 4050 (D) 5050
- 2.9 The number of leaf nodes in a rooted tree of n nodes, with each node having 0 or 3 children is:
 (A) $n/2$ (C) $(n-1)/2$
 (B) $(n-1)/3$ (D) $(2n+1)/3$

2.10 Consider the following algorithm for searching for a given number x in an unsorted array $A[1..n]$ having n distinct values:

1. Choose an i uniformly at random from $1..n$;
2. If $A[i] = x$ then Stop else Goto 1;

Assuming that x is present in A , what is the expected number of comparisons made by the algorithm before it terminates?

- (A) n (C) $2n$
(B) $n - 1$ (D) $n/2$

2.11 The running time of the following algorithm Procedure $A(n)$

If $n \leq 2$ return (1) else return ($A(\lfloor \sqrt{n} \rfloor)$); is best described by

- (A) $O(n)$ (C) $O(\log \log n)$
(B) $O(\log n)$ (D) $O(1)$

2.12 A weight-balanced tree is a binary tree in which for each node, the number of nodes in the left subtree is atleast half and atmost twice the number of nodes in the right sub tree. The maximum possible height (number of nodes on the path from the root to the furthest leaf) of such a tree on n nodes is best described by which of the following?

- (A) $\log_2 n$ (C) $\log_3 n$
(B) $\log_{4/3} n$ (D) $\log_{3/2} n$

2.13 The smallest finite automaton which accepts the language $\{x \mid \text{length of } x \text{ is divisible by } 3\}$ has

- (A) 2 states (C) 4 states
(B) 3 states (D) 5 states

2.14 Which of the following is true?

- (A) The complement of a recursive language is recursive.
(B) The complement of a recursively enumerable language is recursively enumerable.
(C) The complement of a recursive language is either recursive or recursively enumerable.
(D) The complement of a context-free language is context-free

2.15 The Newton-Raphson iteration $X_{n+1} = (M_n/2) + 3/(2X_n)$ can be used to solve the equation

- (A) $X_2 = 3$ (C) $X_2 = 2$
(B) $X_3 = 3$ (D) $X_3 = 2$

- 2.16 Four fair coins are tossed simultaneously. The probability that atleast one head one tail turn up is
- (A) 1 /16 (C) 7 /8
(B) 1 /8 (D) 15/16
- 2.17 The binary relation $S = \phi$ (empty set) on set $A = \{ 1, 2, 3 \}$ is
- (A) Neither reflexive nor symmetric (C) Transitive and reflexive
(D) Transitive and symmetric
(B) Symmetric and reflexive
- 2.18 The C language is:
- (A) A context free language
(B) A context sensitive language
(C) A regular language
(D) Parsable fully only by a Turing machine
- 2.19 To evaluate an expression without any embedded function calls
- (A) One stack is enough
(B) Two stacks are needed
(C) As many stacks as the height of the expression tree are needed
(D) A Turing machine is needed in the general case
- 2.20 Dynamic linking can cause security concerns because
- (A) Security is dynamic
(B) The path for searching dynamic libraries is not known till runtime
(C) Linking is insecure
(D) Cryptographic procedures are not available for dynamic linking
- 2.21 Which combination of the following features will suffice to characterize an OS as a multi-programmed OS? (a) More than one program may be loaded into main memory at the same time for execution. (b) If a program waits for certain events such as I/O, another program is immediately scheduled for execution. (c) If the execution of program terminates, another program is immediately scheduled for execution.
- (A) a (C) a and c
(B) a and b (D) a, b, and c

- 2.22 In the index allocation scheme of blocks to a file, the maximum possible size of the file depends on
- (A) The size of the blocks, and the size of the address of the blocks.
 (B) The number of blocks used for the index, and the size of the blocks.
 (C) The size of the blocks, the number of blocks used for the index, and the size of the address of the blocks.
 (D) None of these
- 2.23 A B^+ - tree index is to be built on the Name attribute of the relation STUDENT. Assume that all student names are of length 8 bytes, disk block are of size 512 bytes, and index pointers are of size 4 bytes. Given this scenario, what would be the best choice of the degree (i.e. the number of pointers per node) of the B^+ -tree?
- (A) 16 (C) 43
 (B) 42 (D) 44
- 2.24 Relation R is decomposed using a set of functional dependencies, F and relation S is decomposed using another set of functional dependencies, G. One decomposition is definitely BCNF, the other is definitely 3NF, but it is not known which is which. To make a guaranteed identification, which one of the following tests should be used on the decompositions? (Assume that the closures of F and G are available).
- (A) Dependency-preservation (C) BCNF definition
 (B) Lossless-join (D) 3NF definition
- 2.25 From the following instance of a relation schema $R(A,B,C)$, we can conclude that:

A	B	C
1	1	1
1	1	0
2	3	2
2	3	2

- (A) A functionally determines B and B functionally determines C
 (B) A functionally determines B and B does not functionally determines C
 (C) B does not functionally determines C
 (D) A does not functionally determines B and B does not functionally determines C

3. Let A be a set of $n (> 0)$ elements. Let N_r be the number of binary relations on A and let N_f be the number of functions from A to A .
- (A) Give the expression for N_r in terms of n (2)
- (B) Give the expression for N_f in terms n . (2)
- (C) Which is larger for all possible n , N_r or N_f (1)
4. (a) $S = \{ \langle 1, 2 \rangle, \langle 2, 1 \rangle \}$ is a binary relation on set $A = \{1, 2, 3\}$. Is it irreflexive ?
Add the minimum number of ordered pairs to S to make it an equivalence relation. Give the modified S .
- (b) Let $S = \{a, b\}$ and let $\mathcal{P}(S)$ be the powerset of S . Consider the binary relation ' \subseteq (set inclusion)' on $\mathcal{P}(S)$. Draw the Hasse diagram corresponding to the lattice $(\mathcal{P}(S), \subseteq)$. (2)
5. (a) Obtain the eigenvalues of the matrix, A
- $$= \begin{bmatrix} 1 & 2 & 34 & 49 \\ 0 & 2 & 43 & 94 \\ 0 & 0 & -2 & 104 \\ 0 & 0 & 0 & -1 \end{bmatrix} \quad (3)$$
- (b) Determine whether each of the following is a tautology, a contradiction, or neither (" \vee " is disjunction, " \wedge " conjunction, " \rightarrow " is implication, " \neg " is negation, and " \leftrightarrow " is biconditional (if and only if). (3)
- (i). $A \leftrightarrow (A \vee B)$
- (ii). $(A \vee B) \rightarrow B$
- (iii). $A \wedge (\neg (A \vee B))$
6. Draw all binary trees having exactly three nodes labelled A, B and C on which Preorder traversal gives the sequence C, B, A . (5)
7. (a) Express the function $f(x, y, z) = xy' + yz'$ with only one complement operation and one or more AND/OR operations. Draw the logic circuit implementing the expression obtained, using a single NOT gate and one or more AND/OR gates.
- (b) Transform the following logic circuit (without expressing its switching function) into an equivalent logic circuit that employs only 6 NAND gates each with 2-inputs (2)

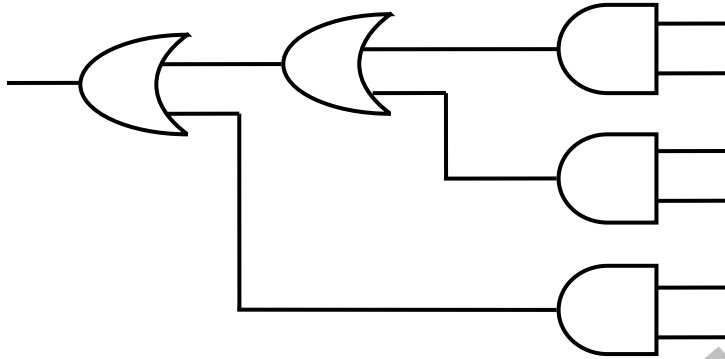

8. Consider the following circuit. $A = a_2a_1a_0$ and b_2b_1, b_0 are three bit binary numbers input to the circuit. The output is $Z = z_3z_2z_1z_0$. R0, R1 and R2 are registers with loading clock shown. The registers are loaded with their input data with the falling edge of a clock pulse (signal CLOCK shown) and appears as shown. The bits of input numbers A, B and the full address are as shown in the circuit. Assume Clock period is greater than the settling time of all circuits.

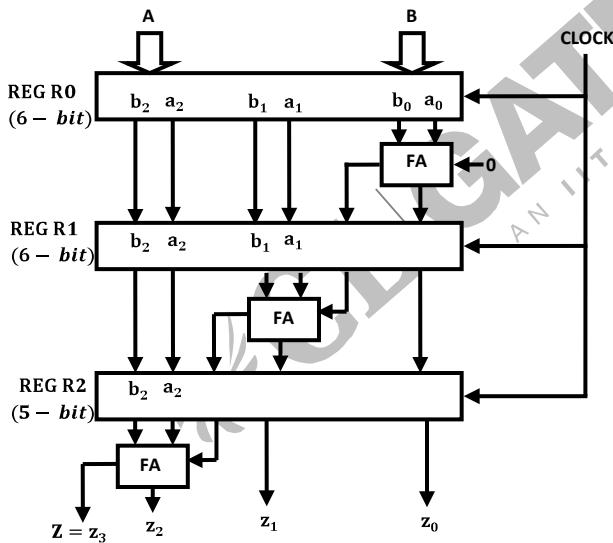

(a) For 8 clocks pulses on the CLOCK terminal and the inputs A ,B as shown, obtain the output Z (sequence of 4 bit value of Z). Assume initial contents of R0 ,R2 and R2 as all zeros.

(3)

A = 110 011 111 101 000 000 000 000
 B = 101 101 011 110 000 000 000 000
 Clock No. 1 2 3 4 5 6 7 8

(b) What does the circuit implement?

(2)

9. Consider the following 32 bit floating point representation scheme as shown in the format below. A value is specific by 3 fields, a one bit sign field (with 0 for positive and 1 for negative values,) a 24 bit fraction field (with the binary point being at the left end of the fraction bits), and a 7 bit exponent field (in excess-64 signed integer representation, with 16 being the base of exponentiation). The sign bit is the most significant bit.

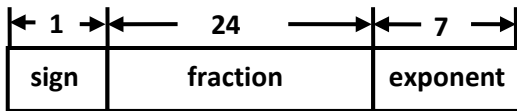

- (a) It is required to represent the decimal value- 7.5 as a normalized floating point number in the given format. Derive the values of the various fields. Express your final answer in hexadecimal. (3)
- (b) What is the largest value that can be represented using this format? Express your answer as the nearest power of 10 (2)
10. In a C program, an array is declared as float A[2048]. Each array is 4 bytes in size, and the starting address of the array is 0x00000000. This program is run on a computer that has a direct mapped data cache of size 8 Kbytes, with block (line) size of 16 Bytes.
- (a) Which elements of the array conflict with elements A[0] in the data cache? Justify your answer briefly. (2)
- (b) If the program accesses the elements of this array one by one in reverse order, i.e., starting with last element and ending with the first elements, how many data cache misses would occur? Justify your answer briefly. Assume that the data cache is initially empty and that no other data or instruction accesses are to be considered. (3)
11. The following recursive function in C is a solution to the Tower of Hanoi problem
- ```
void move (int n, char A, char B, char C)
{
 if (.....) {
 move (.....);
 printf(" Move disk %d from pole % c to pole %c\n", n, A, C);
 move (.....);
 }
}
```
- Fill in the dotted part of the solution
12. Fill in the blanks in the following template of an algorithm to compute all pairs shortest path lengths in a directed graph G with n\*n adjacency matrix A. A[i, j] equals 1, if there is an edge in G from i to j, and 0 otherwise. Your aim in filling in the blanks is to ensure that the algorithm is correct.

```

INITIALIZATION: for i=1.....n
{ for j =n
 { If A [i, j] =0 , then P[i, j]
=..... else P[i, j] = _____;}
}
ALGORITHM: for i=1.....n
 { for j=1.....n
 { for j =1.....n
 {for j =1.....n
 {for k=1.....n
 {P[_,_]= min{_____,_____};}
 }
 }
 }
 }
}

```

- (a) Copy the complete line containing the blanks in the initialization step and fill in the blanks. (1)
- (b) Copy the complete line containing the blanks in the Algorithm step and fill in the blanks. (3)
- (c) Fill in the blank: The running time of the Algorithm is  $O(\_)$ . (1)
13. (a) In how many ways can a given positive integer  $n \geq 2$  be expressed as the sum of 2 positive integers ( which are not necessarily distinct). For example, for  $n = 3$ , the number of ways 2, *i. e.*,  $1+2$ ,  $2+1$ . Give only the answer without any explanation.
- (b) In how many ways can a given positive integer  $n \geq 3$  be expressed as the sum of 3 positive integers( which are not necessarily distinct). For example, for  $n = 4$ , the number of ways is 3, *i.e.*,  $1+1+2$ ,  $1+2+1$ . Give only the answer without explanation. (2)
- (c) In how many ways can be given positive integer  $n \geq k$  be expressed as the sum of  $k$  positive integers ( which are not necessarily distinct)? Give only the answer without explanation. (2)
14. The aim of the following question is to prove that the language  $\{M \mid M \text{ is the code of a Turing Machine which, irrespective of the input, halts and outputs a } 1\}$ , is undecidable. This is to be done by reducing from the language  $\{M', x \mid M' \text{ halts on } x\}$ , which is known to be undecidable. In parts (a) and (b) describe the 2 **main steps in the construction of M**. In part (c) describe the key property which relates the behaviour of  $M$  on its input  $w$  to the behaviour of  $M'$  on  $x$ .
- (a) On input  $w$ , what is the first step that  $M$  must make? (2)
- (b) On input  $w$ , base on the outcome of the first step, what is the second step that  $M$  must make? (2)
- (c) What key property relates the behaviour of  $M$  on  $w$  to the behaviour of  $M'$  on  $x$ ? (1)

15. A university placement centre maintains a relational database of companies that interview students on campus and make job offers to those successful in the interview. The scheme of the database is given below:

- COMPANY (c name , clocation )
- STUDENT (srollno, sname, sdegree)
- INTERVIEW( cname, srollno, idate)
- OFFER( cname, srollno, osalary)

The COMPANY relation gives the name and location of the company. The STUDENT relation gives the student’s roll number, name and the degree program for which the student is registered in the university. The INTERVIEW relation gives the date on which a student is interviewed by a company. The OFFER relation gives the salary offered to a student who is successful in company’s interview. The key for each relation is indicated by the underlined attributes.

- (a) Write relational algebra expressions (using only the operators  $\sigma$ ,  $\pi$ ,  $\cup$ ,  $-$ ) for the following queries: (1)
  - (i) List the roll numbers and names of those students who attended at least one interview but did not receive any job offer.
  - (ii) List the roll numbers and names of students who went for interview and received job offers from every company with which they interviewed. (2)
- (b) Write an SQL query to list, for each degree program in which more than five students were offered jobs, the name of the degree and the average offered salary of students in this degree program. (2)

16. For relation  $R = (L, M, N, O, P)$  the following dependencies hold:

$M \rightarrow O$   $NO \rightarrow P$   $P \rightarrow L$  and  $L \rightarrow MN$

R is decomposed into

$R_1 = (L, M, N, P)$  and

$R_2 = (M, O)$

- (a) Is the above decomposition a lossless- join decomposition? Explain. (1)
- (b) Is the above decomposition dependency- preserving? If not, list all the dependencies that are not preserved. (2)
- (c) What is the highest normal form satisfies by the above decomposition? (2)

17. (a) The following table refers to search times for a key in B- trees and  $B^+$  - trees.

| B-tree            |                     | $B^*$ tree        |                     |
|-------------------|---------------------|-------------------|---------------------|
| Successful search | Unsuccessful search | Successful search | Unsuccessful search |
| $X_1$             | $X_2$               | $X_3$             | $X_4$               |

A successful search means that the key exists in the database and unsuccessful means that it is not present in the database. Each of the entries  $X_1, X_2, X_3$  and  $X_4$  can have a value of either Constant or Variables: Constant means that the search time is the same, independent of the specific key value, whereas Variable means that it is dependent on the specific key value chosen for the search. Give the correct values or the entries  $X_1, X_2, X_3$  and  $X_4$  (for example  $X_1 = \text{Constant}, X_2 = \text{Constant}, X_3 = \text{Constant}, X_4 = \text{Constant}$ ). (1)

(b) Relation R (A,B) has the following view defined on it :

```
CREATE VIEW V, AS
(SELECT R1.A, R2.B
FROM R AS R1, R AS R2
WHERE R1.B=R2.A)
```

(i) The current contents of relation R are shown below. What are the contents of the view V?

| A | B  |
|---|----|
| 1 | 2  |
| 2 | 3  |
| 2 | 4  |
| 4 | 5  |
| 6 | 7  |
| 6 | 8  |
| 9 | 10 |

(ii) The tuples (2,11) and (11, 6) are now inserted into R. What are the additional tuples that are inserted in V? (2)

18. (a) Draw the process state transition diagram of an OS in which (i) each process is in one of the five states: created, ready, running, blocked (i.e., sleep or wait), or terminated, and (ii) only non-preemptive scheduling is used by the OS. Label the transitions appropriately. (2)

(b) The functionality of atomic TEST-AND-SET assembly language instruction is given by the following C function.

```
int TEST-AND-SET (int * x)
{
 A1 : y = * x;
 A2 : * x=1
 A3: return y;
}
```

(i) Complete the following C functions for implementing code for entering and leaving critical

sections based on the above TEST-AND-SET instruction.

```
int mutex = 0;
void enter – cs()
{
while (.....);
}
void leave-cs()
{
.....;
}
```

- (ii) Is the above solution to the critical section problem deadlock free and starvation- free (1)
- (iii) For the above solution, show by an example that mutual exclusion is not ensured if TEST-AND-SET instruction is not atomic (1)

19. A computer system uses 32-bit virtual address, and 32-bit physical address. The physical memory is byte addressable, and the page size is 4 kbytes. It is decided to use two level page table to translate from virtual address to physical address. Equal number of bits should be used for indexing first level and second level page table, and the size of each page table entry is 4 bytes.
- (a) Give a diagram showing how a virtual address would be translated to a physical address. (3)
- (b) What is the number of page table entries that can be contained in each page?
- (c) How many bits are available for storing protection and other information in each page table entry?

20. The following solution to the single-producer single consumer problem uses semaphores for synchronization.

```
#define BUFFSIZE 100
buffer buf[BUFFSIZE];
int first = last = 0;
semaphore b_full = 0;
semaphore b_empty = BUFFSIZE;
void producer ()
{
while(1){
produce an item;
p1:;
put the item into buf [first];
```

```

first = (first+1)% BUFFSIZE;
p2:;
 }
}
void consumer()
{
while(1){
 c1:;
 take the item from buf[last];
 last = (last +1)%BUFFSIZE;
 c2: ;
 consume the item;
}
}

```

- (a) Complete the dotted part of the above solution. (2)
- (b) Using another semaphore variable, insert one line statement each immediately after  $p1$ , immediately before  $p2$ , immediately after  $c1$ , and immediately before  $c2$  so that the program works correctly for multiple producers and consumers. (3)
21. We require a four state automaton to recognize the regular expression  $(a|b)^*abb$ .
- (a) Give an NFA for this purpose. (1)
- (b) Give an DFA for this purpose. (4)
22. (a) Construct all the parse trees corresponding to  $i + j * k$  for the grammar (2)
- $E \rightarrow E + E$
- $E \rightarrow E * E$
- $E \rightarrow id$
- (b) In this grammar, what is the precedence of the two operators  $*$  and  $+$ ? (1)
- (c) In only one parse tree is desired for any string in the same language, what changes are to be made so that resulting LALR(1) grammar is non-ambiguous? (2)